

## Introduction

This document contains information on the Model 2600-KIT Screw Terminal Connector Kit. The kit contains a cable housing and an inverted plug. Use this kit to cable Category I SMU output connections on the rear panel of a Model 260x Series SourceMeter® Instrument to DUTs (Devices Under Test).

**WARNING** Maximum floating (common mode) voltage for an SMU is 250V. Exceeding this level could damage the instrument and create a shock hazard.

Using an external source to float an SMU could create a shock hazard in the test circuit. A shock hazard exists whenever >42V peak is present in the test circuit.

**NOTE** If applicable, remove terminal block(s) before using the Model 2600-KIT. The Model 2602 can use two terminal blocks (one for each SMU channel), the Model 2601 has one terminal block for the single SMU.

A terminal block can be removed from the rear panel by loosening the two captive retaining screws and pulling it off the rear panel.

## Connector description

The inverted plug secures cables to pins for a quick connection to the rear panel SMU connector. Refer to Table 1 for plug specifications.

Table 1  
**Plug specifications**

Characteristic	Specification
Insulation Material Group	I
Nominal Current/Cross Section	12A/2.5mm <sup>2</sup>
Maximum Load Current/Cross Section	12A/2.5mm <sup>2</sup>
Connection Capacity	24–12AWG
UL and CSA Approval Data:	
Nominal Voltage	250V
Current	12A
Conductor Sizes	24–12AWG

The green cable housing provides for cable diameters of 6–13.5mm. Marker strips and a transparent label carrier are included. Use supplementary insulation as applicable.

To cable a connector (refer to Figure 1):

1. Determine wiring requirements and pinouts (see Table 2).
2. Split cable housing into upper and lower halves.
3. Loosen strain relief screws.
4. Thread wire and cabling into housing through strain relief.
5. Connect wires to the inverted plug. Make connections to the applicable screw terminals for the determined wiring requirements.
6. Snap housing halves together.
7. Secure cable with strain relief.

*Figure 1*  
**Connector assembly**

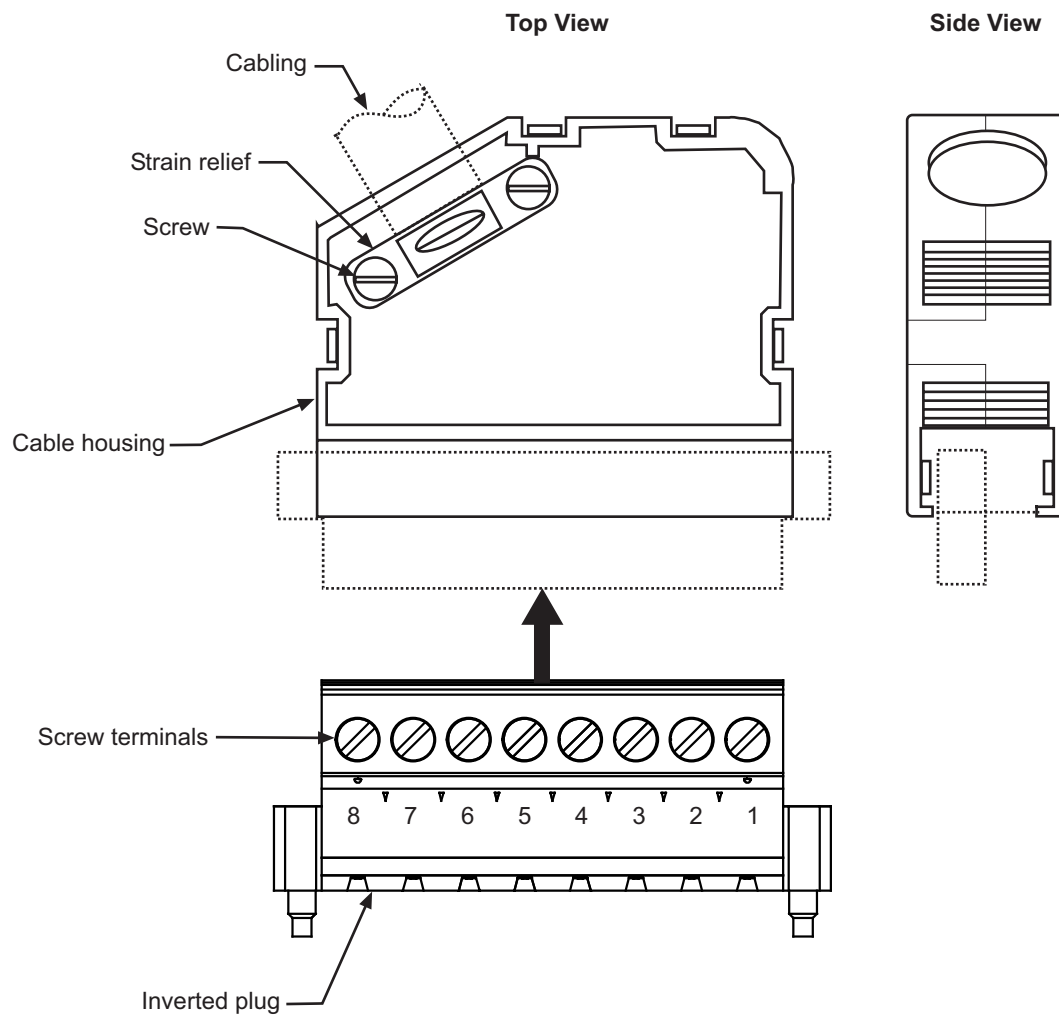
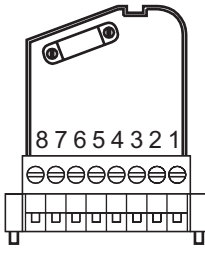

Table 2  
Connector pinouts

Pin No.	Connector	Figure
1	LO	
2	Sense LO	
3	G	
4	HI	
5	G	
6	G	
7	G	
8	Sense HI	

## Connection

Refer to Figure 2 for a typical instrument connector location. Refer to the specific instrument's user manual for additional connection information.

**WARNING** Do not exceed the voltage rating for the wiring used or for the Model 260x. Make sure connections at both ends do not exceed the rated specifications.

Failure to follow this warning may result in injury from electrical shock as well as damage to the equipment.

Figure 2  
Typical instrument connector

